

# LK-F45•47 \*TC\* (PVDF)

No. 85-084  
June 1st, 2020

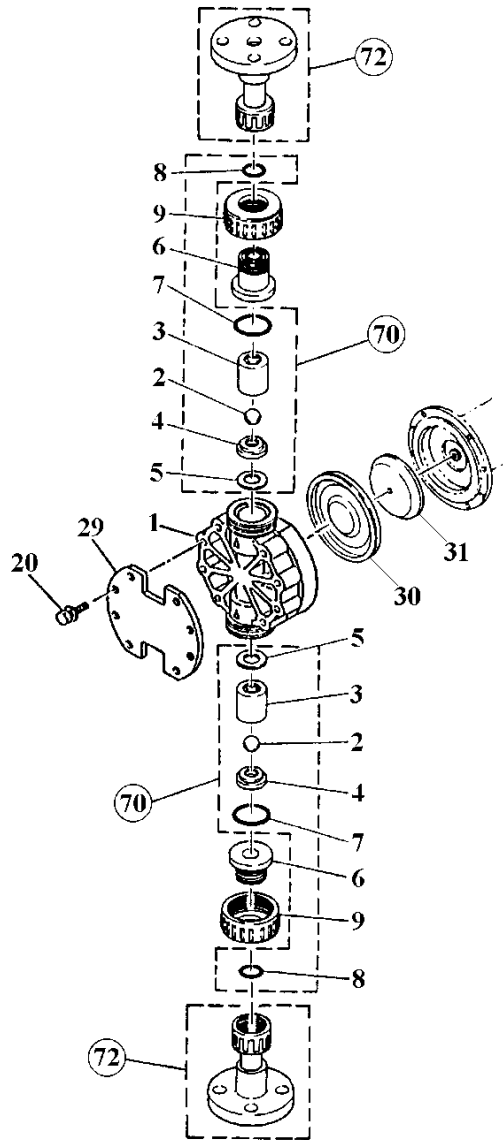

Item	Description	Q'ty	Material	LK-F45•47TC	
				Part No.	
1	Pump Head	1	CFRPVDF	L1505	
2	Valve Ball	2	Alumina Ceramic	EH0664	
3	Valve Guide	2	CFRPVDF	L0347	
4	Valve Seat	2	CFRPVDF	L0348	
5	Valve Gasket	2	PTFE	L0097	
6	Adapter	2	CFRPVDF	L0350	
7	O-Ring, P-32	2	FKM-A	L0103	
8	O-Ring, P-20	2	FKM-A	L0016	
9	Nut	2	CFRPVDF	L1539	
20	Hex. Bolt with S.W., M8x60	8	SUS304	L1166	
29	Reinforcing Plate	1	Steel	L1224	
30	Diaphragm	1	PTFE (+EPDM)	L0109	
31	Retainer Plate	1	SUS304	L0110	
70	Valve Set	2		L0359	
72	Flange Unit <T> "DN 15"	2	PVDF+(GFRPP)		

\*Note: Item No.72 (DIN Flange Unit) is to be quoted on request.

⚠ Subject to change without prior notice! ⚠ Actual pump may differ from the exploded view!

# LK-F \*Drive Unit\*

No. 85-087  
June 1st, 2020

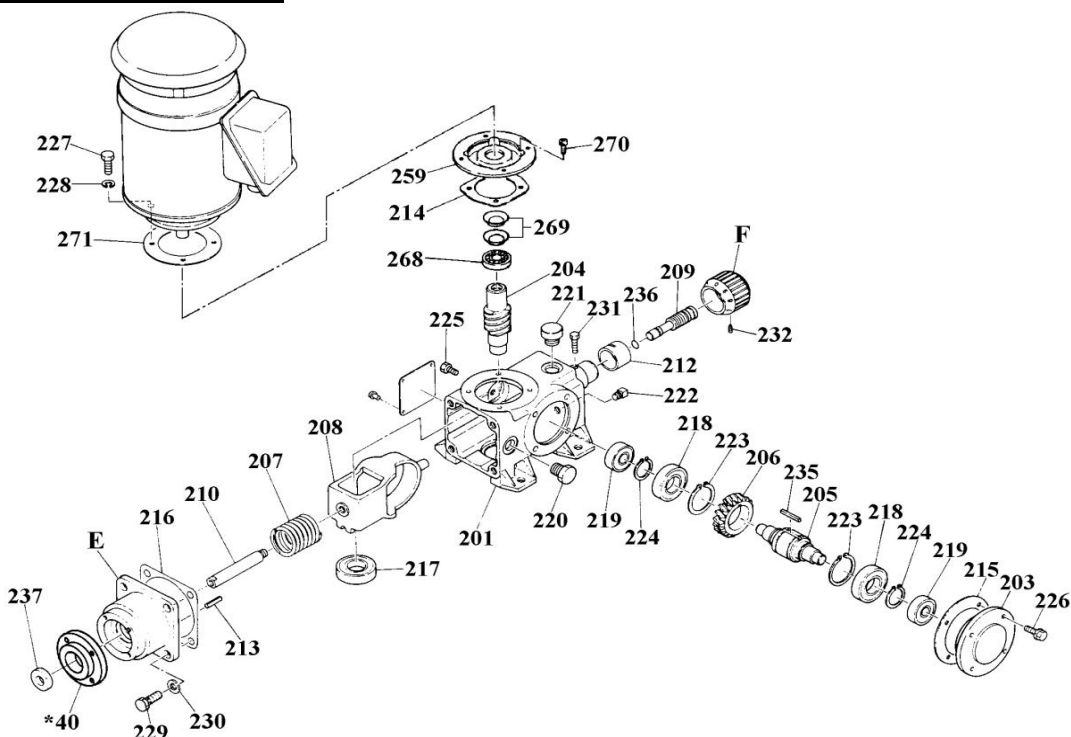

Item	Description	Q'ty	Remark	Part No.
*40	Adapter Bracket	1	LK-F11	L1607
201	Case (ADC12)	1	LK-F11	L1601
		1	LK-F2•4•5	L1602
		1	LK-F3( )	L1603
		1	LK-F5( )	L1603
E	Bracket Ass'y (FC200) with Spring Pin <Item 213> and Oil Seal <Item 237>	1	LK-F11	L1128
		1	LK-F2( )	L1129
		1	LK-F3( )	L1130
		1	LK-F4( )	L1131
		1	LK-F5( )	L1132
203	Bearing Holder	1	ADC12	L1608
204	Worm (Steel)	1	LK-F( )1•5	L1263
		1	LK-F( )2•7	L1264
205	Worm Wheel Shaft (Steel)	1	LK-F11	L1133
		1	LK-F2( )	L1134
		1	LK-F3( )	L1135
		1	LK-F4( )	L1136
		1	LK-F5( )	L1137
206	Worm Wheel (Al.+B.Casting)	1	LK-F( )1•5	L1103
		1	LK-F( )2•7	L1104
207	Spring	1	Steel	L1146
208	Slider	1	Steel	L1105
209	Stroke Length Shaft (Steel)	1	LK-F11	L1710
		1	LK-F2•4•5	L1711
		1	LK-F3( )	L1712
210	Pump Shaft (Steel)	1	LK-F1•2	L1138
		1	LK-F3( )	L1139
		1	LK-F4( )	L1140
		1	LK-F5( )	L1141
F	Dial with Set-screw <Item 232> (ABS+S4 equiv.)	1	LK-F1•2•3	L1415
		1	LK-F4( )	L1416
		1	LK-F5( )	L1417

Item	Description	Q'ty	Remark	Part No.
212	Stroke Length Scale (ABS)	1	LK-F11	L0754
		1	LK-F2•3	L0980
		1	LK-F4( )	L0982
		1	LK-F5( )	L0983
213	Spring Pin (4x40)	1	Steel	L1106
214	Gasket A	1		L1524
215	Gasket B	1		L1525
216	Gasket C	1		L1526
217	Roller Bearing	1	4T-30203	L1112
218	Ball Bearing	2	16004	L1111
219	Ball Bearing	2	6201	L1110
220	Oil Gauge (3/8")	1		L0752
221	Oil Cap (3/8")	1		L1400
222	Plug	1	SUS304	L1113
223	Retaining Ring	2	Steel	L1115
224	Retaining Ring	2	Steel	L1114
225	Waher F. Bolt	1	M6x5	L1713
226	Waher F. Bolt	4	M6x15	L1714
227	Hex. Bolt (M8x20)	4	S4 equiv.	L0761
228	Spr. Washer (M8)	4	S4 equiv.	L1512
229	Bolt (M8x20)	4	Steel	L1715
230	Spr. Washer (M8)	4	Steel	L1678
*231	Cap Bolt (M5x15)	1	S4 equiv.	L0757
232	Setscrew (M4x10)	1	S4 equiv.	L0756
235	Key (4x4x15)	1	Steel	L1121
236	O-Ring (P-7)	1	NBR	L1122
237	Oil Seal (12x25x7)	1	NBR	L0794
259	Motor Adapter	1	FC200	L1265
268	Ball Bearing	1	60/22ZZ	L1266
269	Belleville Spring	2		L1267
270	Cap Bolt (M5x30)	4	Steel	L1268
271	Gasket	1		L1527

\*Notes: (1) Item 40 (Adapter Bracket in FC200) is for "LK-F11" only.  
(2) Item 231 (Cap Bolt, M5x15) is to be quoted on request.

⚠ Subject to change without prior notice! ⚠ Actual pump may differ from the exploded view!