

MDM 32-1-PKKC-(H) =PFA=

No. 60-165
Sep. 01, 2016

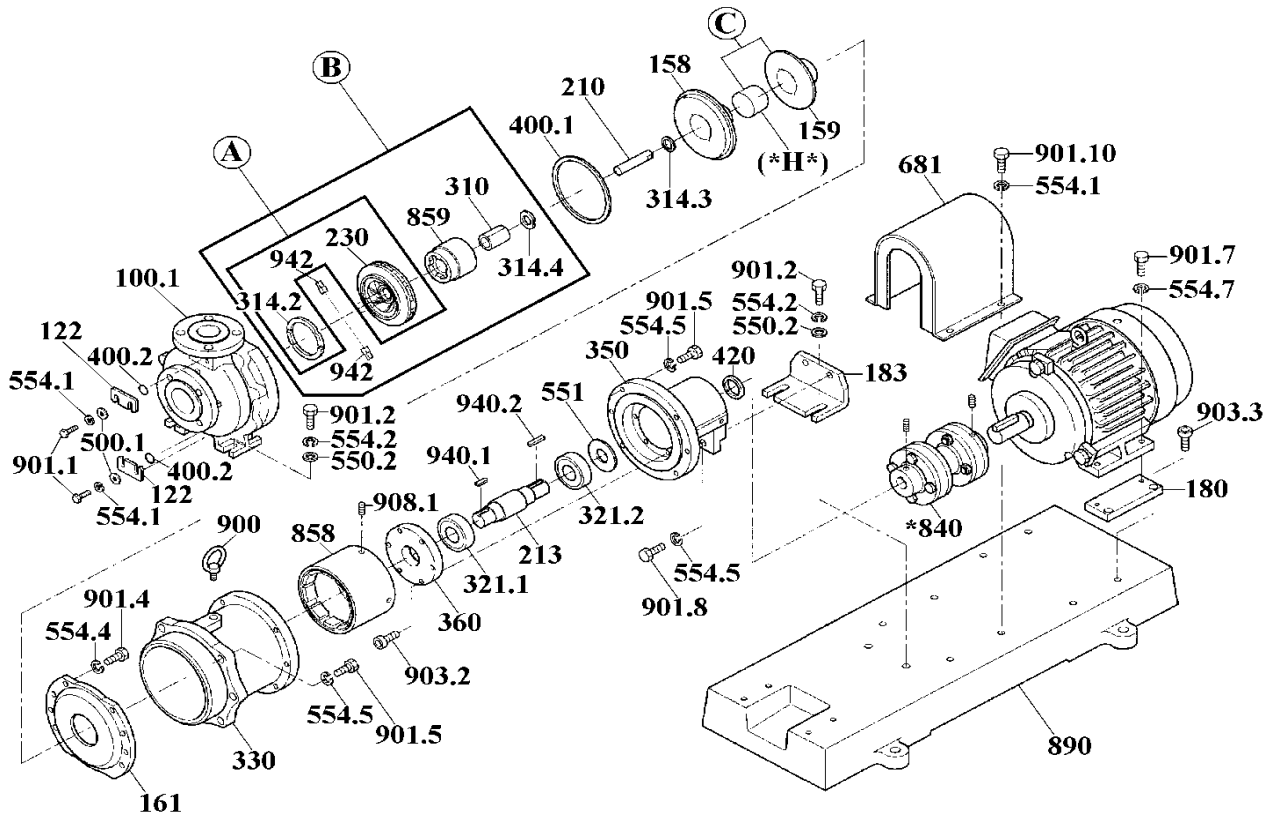

Item	Description	Q'ty	Remarks	MDM32-1-PKKC		MDM32-1-PKKC-*H*		
				Part No.	Code No.	Part No.	Code No.	
100.1	F. Casing with Air/Drain Hole	1	PFA+SiC+ Ductile Iron	MDM1007	1231150620	↔	↔	
	Unit (ISO) less Air/Drain Hole	1		MDM1006	1231150610	↔	↔	
122	Air Vent Plate•Drain Plate	2	Steel	MDM0009	1240485700	↔	↔	
158	Rear Casing	1	PFA	MDM0210	1220263100	MDM1014	1231139600	
159	Rear Casing Cover	1	FRP	MDM0212	1220262300			
C	Rear Casing Cover Unit	1	FRP			MDM1032	1231151700	
161	Rear Casing Support	1	Ductile Iron	MDM1015	1210039600	↔	↔	
183	Support	1	Steel	MDM1017	1231137800	↔	↔	
210	Spindle	1	SiC	MDM0121	1240680200	↔	↔	
230	Impeller <PFA> "50Hz" [P32/40]	165	1	Ø 165 mm	MDM0215	1230899910	↔	↔
		160	1	Ø 163 mm	MDM1033	1231150700	↔	↔
		150	1	Ø 150 mm	MDM0217	1230899930	↔	↔
		140	1	Ø 140 mm	MDM0219	1230899950	↔	↔
		130	1	Ø 130 mm	MDM0220	1230899960	↔	↔
		120	1	Ø 120 mm	MDM0221	1230899970	↔	↔
314.2	Mouth Ring	1	SiC	MDM0018	1240684600	↔	↔	
A	Impeller+Mouth R. Ass'y (230+314.2)	165	1	Ø 165 mm	MDM0223	1230900810	↔	↔
		120~160	1	Ø120~163mm	<Specify impeller size.>		↔	↔
310	Bearing	1	SiC	MDM0123	1240680900	↔	↔	
314.3	Rear Thrust Ring	1	PTFE (Natural)	MDM0614	1240690700	↔	↔	
314.4	Rear Ring	1	SiC	MDM0126	1240680800	↔	↔	
330	Bracket	1	Ductile Iron	MDM1021	1210039800	↔	↔	
400.1	Gasket	1	PTFE	MDM0214	1230889500	↔	↔	
400.2	Gasket, Air V.•Drain (D•E)	2	PTFE	MDM0025	1240485900	↔	↔	
*858	Drive Magnet Unit *See Note	1	4,0•5,5•7,5kW	MDM1026	1220298910	↔	↔	
859	Magnet Capsule [P10]	1	PFA+R.E.Mag	MDM0287	1230897020	↔	↔	
B	Impeller+Magnet Capsule Assembly	165	1	4,0•5,5•7,5kW	MDM0580	2270140410	↔	↔
		120~160	1		<Specify impeller size.>		↔	↔
890	Base Plate (A•D) 4,0~7,5kW	1	Grey Iron	MDM9993	1220193700	↔	↔	
942	Impeller Pin	2	PFA	MDM0138	1240681900	↔	↔	

*Note: "Drive Magnet Unit" is furnished with 2 x Setscrew (908.1).

⚠ Subject to change without prior notice! ⚠ Actual pump may differ from the exploded view!

MDM32-1•40-1-C-(H)•(T)

No. 60-166c
Sep. 01, 2016

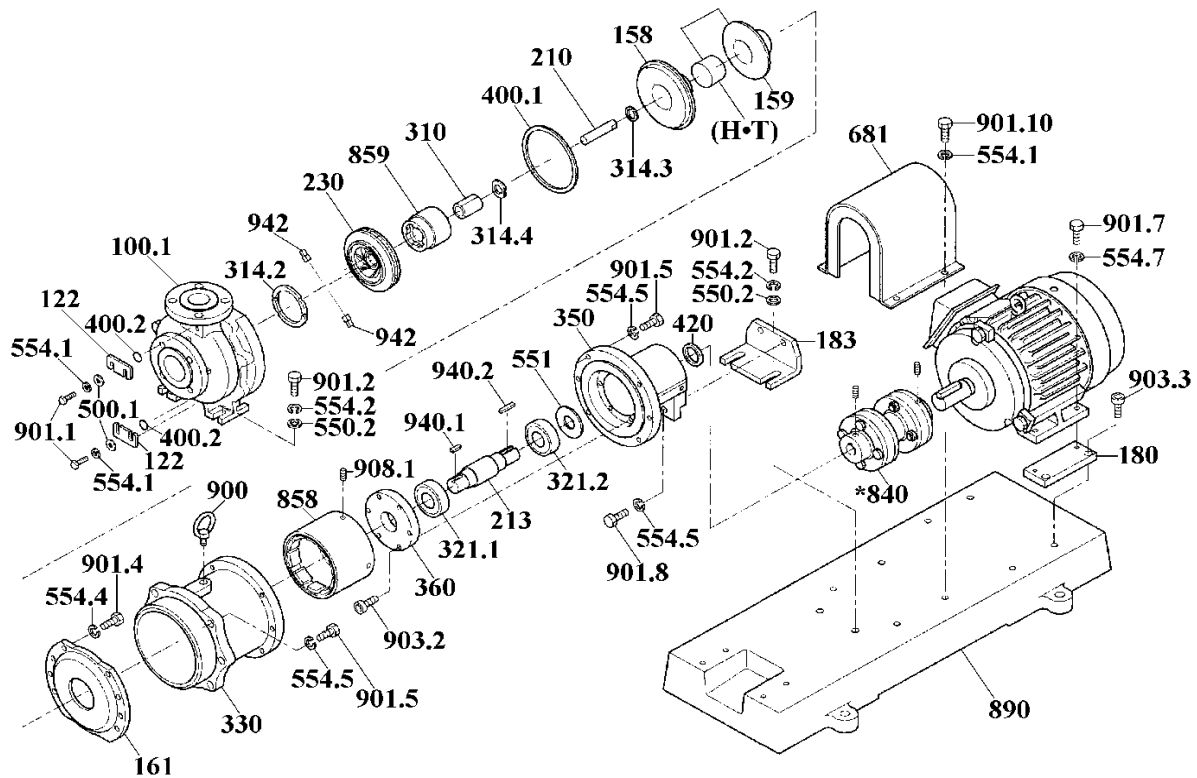

Item	Description	Q'ty	Material	Part No.	Code No.
180	Motor Spacer <4,0kW only>	A•D	2	Steel	MDM9992 1240486100
213	Drive Shaft	1	Steel	MDM1031	1231137600
321.1	Ball Bearing <6308ZZ>	1		MDM1020	0280100275
321.2	Ball Bearing <6208ZZ>	1		MDM1019	0280100274
350	Bearing Housing	1	Ductile Iron	MDM1023	1210040800
360	Bearing Cover	1	Steel	MDM1024	1231137700
420	Shaft Seal	1	NBR+SUS304	MDM1081	0300300199
681	Coupling Cover <A•D>	4,0kW	1	Steel	MDM9991 1220200710
		5,5•7,5kW	1	Steel	MDM9990 1220200720
*840	Coupling	A•D	1	*Please contact IWAKI for details!	
900	Eye Bolt (M12)	1	Steel	MDM0036	0150800003
940.1	Key <10x8x30>	1	Steel	MDM1030	0155300048
* 940.2	Key <8x7x40>	1	Steel	MDM1089	0155300049
* 500.1	Plate Washer (Drain•Air Vent Plate) M8	4	A4 (SUS316 eq.)	MDM0026	0153500074
* 550.2	Plate Washer (Base•Support) M12	A•D	6	A4 (SUS316 eq.)	MDM0027 0153500029
551	Wave Washer (Drive Shaft)	1	Spring Steel	MDM1025	0154300026
* 554.1	Spring Washer (Drain•Air Vent•C.Cover) M8	8	A4 (SUS316 eq.)	MDM0028	0154100057
* 554.2	Spring Washer (Base•Support) M12	A•D	6	A4 (SUS316 eq.)	MDM0029 0154100024
* 554.4	Spring Washer (Cover) M16	8	A4 (SUS316 eq.)	MDM0490	0154100026
* 554.5	S.W. (Bearing Housing•Bracket•Support) M12	10	A4 (SUS316 eq.)	MDM0029	0154100024
* 554.7	Spring Washer (Motor) M10	4,0~7,5kW	4	A4 (SUS316 eq.)	MDM0030 0154100022
* 901.1	Hex. Bolt (Drain•Air Vent Plate) M8x20	4	A4 (SUS316 eq.)	MDM0037	0150100163
* 901.2	Hex. Bolt (Base•Support) M12x35	A•D	6	A4 (SUS316 eq.)	MDM0136 0150100207
* 901.4	Hex. Bolt (Cover) M16x45	8	A4 (SUS316 eq.)	MDM0491	0150100240
* 901.5	Hex. Bolt (B. Housing•Bracket) M12x35	8	A4 (SUS316 eq.)	MDM0136	0150100207
* 901.7	Hex. Bolt (Motor) M10x30	4,0~7,5kW	4	A4 (SUS316 eq.)	MDM0040 0150100182
* 901.8	Hex. Bolt (Support) M12x30	2	A4 (SUS316 eq.)	MDM0042	0150100206
* 901.10	Hex. Bolt (Coupling Cover) M8x16	A•D	4	A4 (SUS316 eq.)	MDM9988 0150100162
** 903.2	Cap Bolt (Bearing Housing) M6x20	6	A4 (SUS316 eq.)	MDM0043	0150300093
* 903.3	Cap Bolt (Motor Spacer) M10x25 <4,0kW only>	4	A4 (SUS316 eq.)	MDM9987	0150300118
908.1	Setscrew (Drive Magnet Unit) M8x10	2	Steel	MDM0044	0152100046

△ Subject to change without prior notice! △ Actual pump may differ from the exploded view!