

MDM 32-2-ECFF-(H) =ETFE=

No. 60-059
Mar. 01, 2006

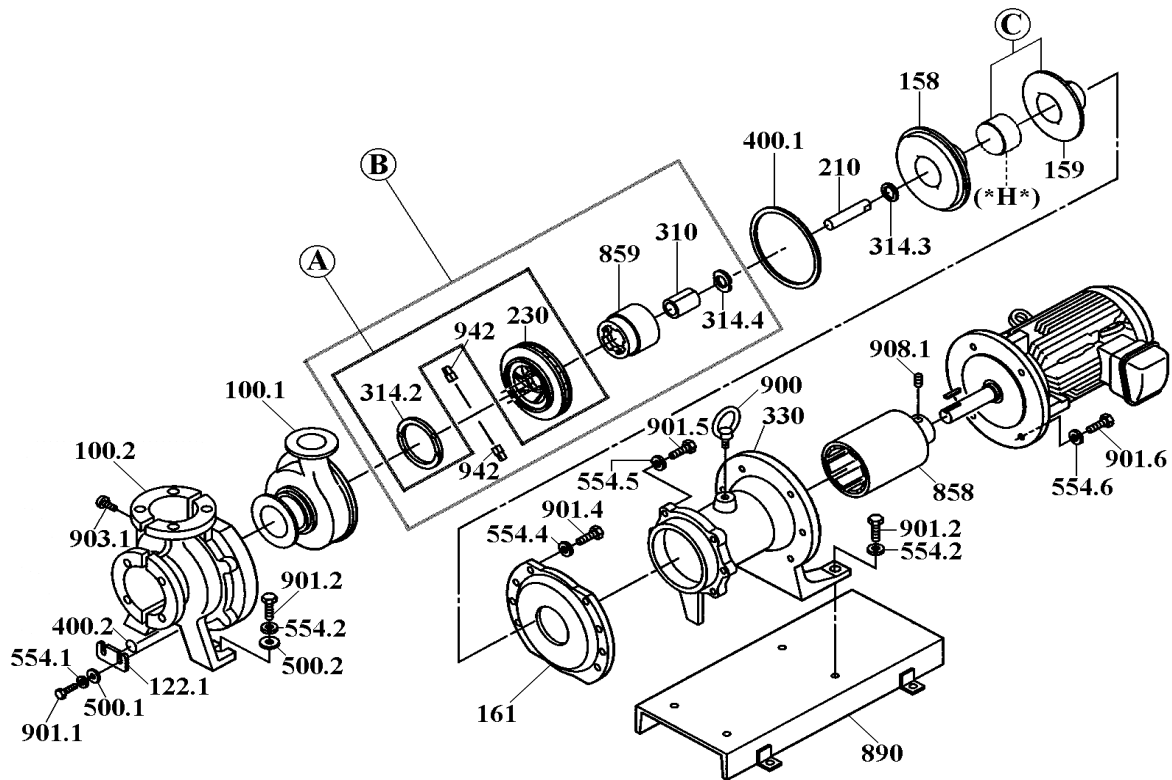

Item	Description	Q'ty	Remarks	MDM32-2-ECFF		MDM32-2-ECFF-*H*		
				Part No.	Code No.	Part No.	Code No.	
100.1	Front Casing (D•E)	1	with Drain Hole	MDM1002	1231078600	ï	ï	
	" " (A•B)	1	less Drain Hole	MDM1000	1210039400	ï	ï	
100.2	*Cover Unit (ISO) <Ductile Iron>	1	5,5•7,5kW	MDM0887	1210035300	ï	ï	
		1	11,0•15,0kW	MDM0890	1210035600	ï	ï	
158	Rear Casing	1	CFRETFE	MDM0371	1220261900			
		1	PFA			MDM0877	1231038800	
159	Rear Casing Cover	1	FRP	MDM0119	1220262400			
C	Rear Casing Cover Unit	1	FRP			MDM0908	1231063520	
230	Impeller <CFRETFE> [E32/40-2] 50•60Hz	225	1	Ø 225 mm	MDM0764	1231038910	ï	ï
		220	1	Ø 220 mm	MDM0765	1231038920	ï	ï
		210	1	Ø 210 mm	MDM0766	1231038930	ï	ï
		200	1	Ø 200 mm	MDM0767	1231038940	ï	ï
		190	1	Ø 190 mm	MDM0768	1231038950	ï	ï
		180	1	Ø 180 mm	MDM0769	1231038960	ï	ï
		170	1	Ø 170 mm	MDM0770	1231038970	ï	ï
		160	1	Ø 160 mm	MDM0771	1231038980	ï	ï
314.2	Mouth Ring	1	PTFE	MDM0951	1240811100	ï	ï	
A	Impeller+Mouth Ring Assembly (230+314.2)	1	Ø 225 mm	MDM0918	1231079110	ï	ï	
		1	Ø160~220mm	<Specify impeller size.>		ï	ï	
210	Spindle	1	Al. Ceramic	MDM0373	1240680300	ï	ï	
310	Bearing	1	Carbon	MDM0950	1240813600	ï	ï	
314.3	Rear Thrust Ring	1	PTFE	MDM0378	1240681200	MDM0615	1240690800	
314.4	Rear Ring	1	Al. Ceramic	MDM0127	1240680700	ï	ï	
859	Magnet Capsule	5,5•7,5kW [10]	1	CFRETFE+Mg.	MDM0288	1230894420	ï	ï
		11,0•15,0kW [15]	1	CFRETFE+Mg.	MDM0470	1230894500	ï	ï
B	Impeller+Magnet Capsule Ass'y (230+310+314.2+ 314.4+859+942)	225	1	5,5•7,5 kW	MDM0934	2270204510	ï	ï
		160~220	1		<Specify impeller size.>		ï	ï
		225	1	11,0•15,0 kW	MDM0942	2270204610	ï	ï
		160~220	1		<Specify impeller size.>		ï	ï

*Note: "Cover Unit" is furnished with 5 x Cap Bolt (903.1).

△ Subject to change without prior notice! △ Actual pump may differ from the exploded view!

MDM 32-2-E•P (ETFE•PFA)

No. 60-061c
Mar. 01, 2006

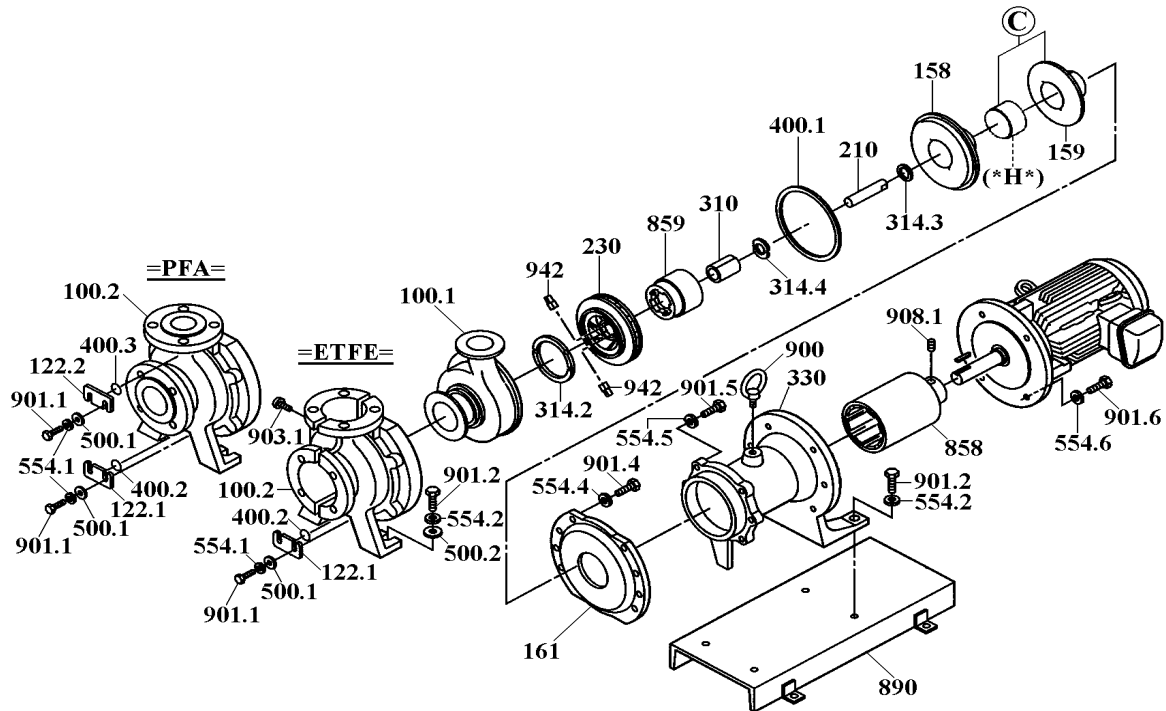

Item	Description	Quantity		Material	Part No.	Code No.		
		ETFE	PFA					
122.1	Drain Plate	1	1	Steel	MDM0009	1240485700		
122.2	Air Vent Plate		1	Steel	MDM0009	1240485700		
161	Rear Casing Support	1	1	Ductile Iron	MDM0878	1220290400		
330	Foot Support	5,5•7,5kW (IEC132)	1	1	Ductile Iron	MDM0129	1220260500	
		11,0•15,0kW (IEC160)	1	1	Ductile Iron	MDM0467	1220260600	
400.1	Gasket	1	1	PTFE	MDM0130	1230889600		
400.2	Drain Gasket	D•E	1	1	PTFE	MDM0025	1240485900	
400.3	Air Vent Gasket	D•E		1	PTFE	MDM0025	1240485900	
*858	Drive Magnet Unit	5,5•7,5kW [DJ10]	1	1	Steel+R.E.Mag.	MDM0286	1220280030	
		11,0•15,0kW [DJ15]	1	1	Steel+R.E.Mag.	MDM0738	1220291100	
890	Base Plate (A•D)	5,5•7,5kW	1	1	Steel	MDM0135	1230891800	
		11,0•15,0kW	1	1	Steel	MDM0471	1230889900	
900	Eye Bolt (M12)	1	1	Steel	MDM0036	0150800003		
942	Impeller Pin	2	2	PFA	MDM0138	1240681900		
500.1	Plate Washer (Drain•Air Vent Plate) M8	2	4	SUS304 equiv.	MDM0026	0153500074		
500.2	Plate Washer (Base) M12	A•D	2	2	SUS304 equiv.	MDM0027	0153500029	
554.1	Spring Washer (Drain•Air Vent Plate) M8	2	4	SUS304 equiv.	MDM0028	0154100057		
554.2	Spring Washer (Base) M12	A•D	4	4	SUS304 equiv.	MDM0029	0154100024	
554.4	Spring Washer (Cover) M16	10	10	SUS304 equiv.	MDM0490	0154100026		
554.5	Spring Washer (Rear Casing Support) M12	4	4	SUS304 equiv.	MDM0029	0154100024		
554.6	" " (Motor)	5,5•7,5kW	M12	4	4	SUS304 equiv.	MDM0029	0154100024
		11,0•15,0kW	M16	4	4	SUS304 equiv.	MDM0490	0154100026
901.1	Hex. Bolt (Drain•Air Vent Plate) M8x20	2	4	SUS304 equiv.	MDM0037	0150100163		
901.2	Hex. Bolt (Base) M12x40	A•D	4	4	SUS304 equiv.	MDM0555	0150100208	
901.4	Hex. Bolt (Cover) M16x45	10	10	SUS304 equiv.	MDM0491	0150100240		
901.5	Hex. Bolt (Rear Casing Support) M12x35	4	4	SUS304 equiv.	MDM0136	0150100207		
901.6	Hex. Bolt (Motor)	5,5•7,5kW	M12x45	4	4	SUS304 equiv.	MDM0137	0150100209
		11,0•15,0kW	M16x45	4	4	SUS304 equiv.	MDM0491	0150100240
903.1	Cap Bolt (Cover) M6x20	5		Steel	MDM0043	0150300093		
908.1	Setscrew (Drive Magnet Unit) M8x10	2	2	Steel	MDM0044	0152100046		

*Note: "Drive Magnet Unit" is furnished with 2 x Setscrew (908.1).

⚠ Subject to change without prior notice! ⚠ Actual pump may differ from the exploded view!