

Item	Description	Q'ty	Remarks	Part No.	Code No.	
100.1	Front Casing Unit (ISO)	with Air•Drain Hole	1	ETFE+Ductile	MDW0050	1231204320
		less Air•Drain Hole	1	Iron	MDW0051	1220311320
122	Air Vent Plate • Drain Plate	2	Steel	MDW0003	1240859500	
158	Rear Casing	1	PFA	MDW0004	1231213800	
159	Rear Casing Cover	1	FRP	MDW0005	1220311700	
159.1	Reinforce Pipe	1	FRP	MDW0006	1231213900	
161	Rear Casing Support	1	Ductile Iron	MDW0007	1220311800	
183.1	Support	1	Steel	MDW0052	1220312200	
183.2	Bracket Spacer	1	Steel	MDW0053	1240859600	
213	Drive Shaft	1	Steel	MDW0009	1220312000	
230	Impeller <CFRETFE> "50Hz"	255	1	Ø 265 mm	MDW0054	1231214910
		250	1	Ø 260 mm	MDW0055	1231214920
		240	1	Ø 250 mm	MDW0056	1231214930
		230	1	Ø 240 mm	MDW0057	1231214940
		220	1	Ø 230 mm	MDW0058	1231214950
		210	1	Ø 220 mm	MDW0059	1231214960
		200	1	Ø 210 mm	MDW0060	1231214970
190	1	Ø 200 mm	MDW0061	1231214980		
310	Bearing	1	SiC	MDW0018	1231204800	
314	Thrust	1	SiC	MDW0019	1231204900	
321	Ball Bearing <6308ZZ>	2		MDE0474	0280100068	
330	Bracket	1	Ductile Iron	MDW0021	1210046800	
337	Split Plate	1	PFA+Ductile Iron	MDW0022	1210046600	
A	Split Plate Assembly (310+314+337)	1		MDW0023	2231204700	
350	Bearing Housing	1	Ductile Iron	MDW0024	1220311900	
360	Bearing Cover	1	Steel	MDW0025	1231205400	
370	Sleeve	1	SiC	MDW0026	1231206800	
400	Air Vent Gasket • Drain Gasket	D•E	2	PTFE	MDE0742	1240653300
400.1	Gasket (Front)		1	PTFE	MDE0711	1240613000
400.2	Gasket (Rear)		1	PTFE	MDE0484	1240593900
412.1	O-Ring <AS568-132>		1	Kalrez®	MDW0030	0325500353
412.2	O-Ring <P-30>		1	Kalrez®	MDW0031	0325100532
903.2	Cap Bolt (Bracket Spacer) <M10x55>		2	Steel	MDW0079	0150300124

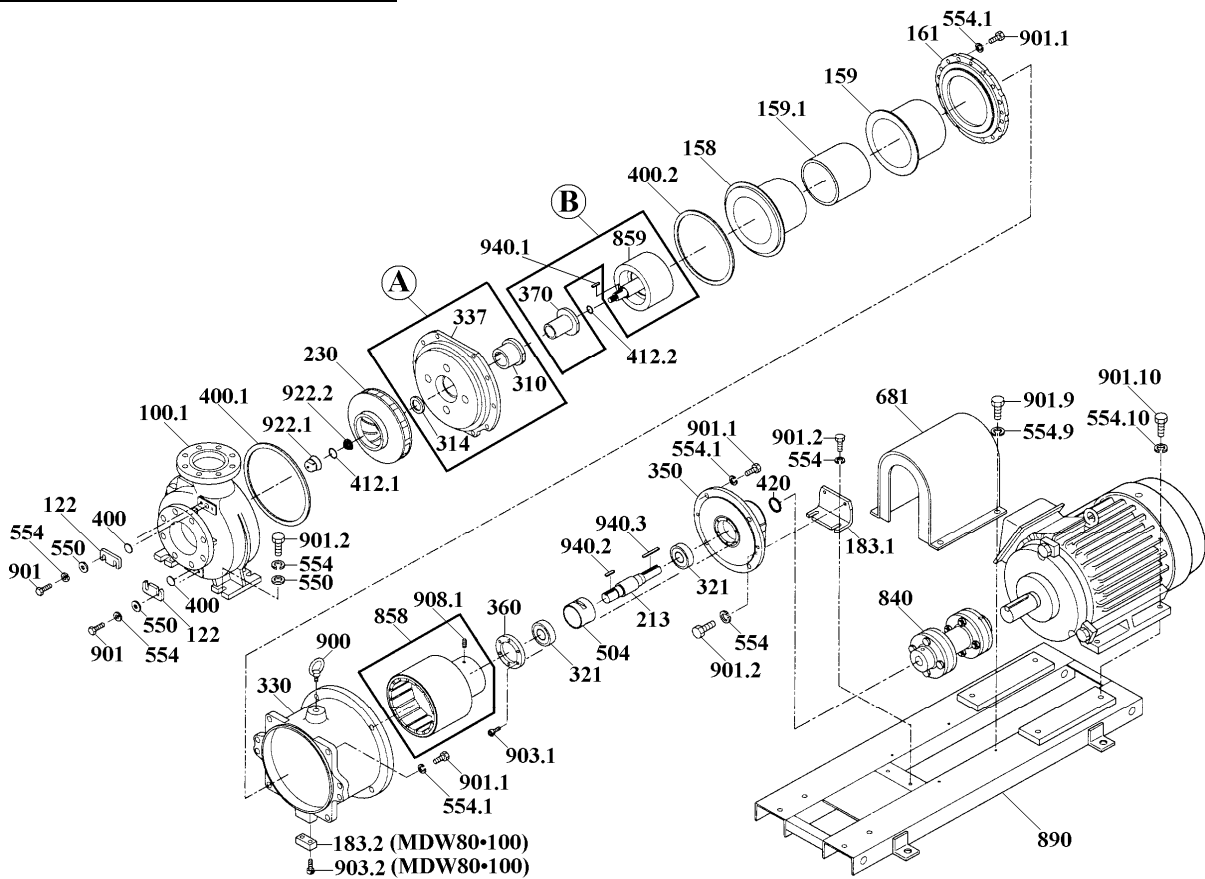

Item	Description	Q'ty	Remarks	Part No.	Code No.	
420	Oil Seal	1	NBR	MDW0032	0300300204	
504	Bearing Spacer	1	Steel	MDW0033	1240859800	
550	Plate Washer <M12>	8	SUS304 equiv.	MDM0027	0153500029	
554	Spring Washer <M12>	12	SUS304 equiv.	MDM0029	0154100024	
554.1	Spring Washer <M16>	26	SUS304 equiv.	MDM0490	0154100026	
554.9	Spring Washer (Coupling Cover) <M8>	4	SUS304 equiv.	MDM0028	0154100057	
554.10	S. Washer (Motor) <M12>	11•15•18,5•22kW	4	SUS304 equiv.	MDM0029	0154100024
	S. Washer (Motor) <M16>	30•37•45kW	4	SUS304 equiv.	MDM0490	0154100026
	S. Washer (Motor) <M20>	55•75kW	4	SUS304 equiv.		
681	Coupling Cover	A•D	1	** Please contact IWAKI for details! **		
840	Coupling	A•D	1	** Please contact IWAKI for details! **		
*858	Drive Magnet Unit <*See Note>		1	Steel+R.E.Mag.	MDW0037 1231205200	
859	Magnet Capsule		1	PFA+R.E.Mag.	MDW0038 1231206400	
B	Magnet Capsule Assembly (859+370)		1	PFA+R.E.Mg.+SiC	MDW0039 2231206300	
890	Base	A•D	1	** Please contact IWAKI for details! **		
900	Eye Bolt (Bracket) <M16>		1	Steel	MDE0528 0150800005	
901	Hex. Bolt (Drain•Air Vent Plate) <M12x30>		4	SUS304 equiv.	MDM0042 0150100206	
901.1	Hex. Bolt <M16x40>		26	SUS304 equiv.	MDE0529 0150100613	
901.2	Hex. Bolt <M12x35>		8	SUS304 equiv.	MDM0136 0150100207	
901.9	Hex. Bolt (Coupling Cover) <M8x15>		4	SUS304 equiv.	MDE0116 0150100162	
901.10	Hex. Bolt (Motor) M12x40	11•15•18,5•22kW	4	SUS304 equiv.	MDM0555 0150100208	
	Hex. Bolt (Motor) M16x50	30•37(2P)kW	4	SUS304 equiv.		
	Hex. Bolt (Motor) M16x55	37(4P)•45kW	4	SUS304 equiv.	MDE0724 0150100242	
	Hex. Bolt (Motor) M20x60	55kW	4	SUS304 equiv.		
	Hex. Bolt (Motor) M20x70	75kW	4	SUS304 equiv.		
903.1	Cap Bolt (Bearing Cover) <M6x20>		6	Steel	MDM0043 0150300093	
908.1	Setscrew (Drive Magnet Unit) <M10x15>		2	Steel	MDW0045 0152100055	
922.1	Impeller Nut		1	PFA+SUS304	MDW0046 1231206900	
922.2	Impeller Lock Nut		1	SUS304	MDW0047 1240860900	
940.1	Key (Magnet Capsule) <8x7x32>		1	Steel	MDW0048 1240861000	
940.2	Key (Drive Shaft, Front) <10x8x40>		1	Steel	MDE0571 1240593400	
940.3	Key (Drive Shaft, Rear) <10x8x75>		1	Steel	MDW0078 0155300059	

\*Note: "Drive Magnet Unit" (858) is furnished with 2 x Setscrew (908.1).

△ Subject to change without prior notice! △ Actual pump may differ from the exploded view!