

SMX-F220•221•222

No. **SMXF22001A**
August 1st, 2019

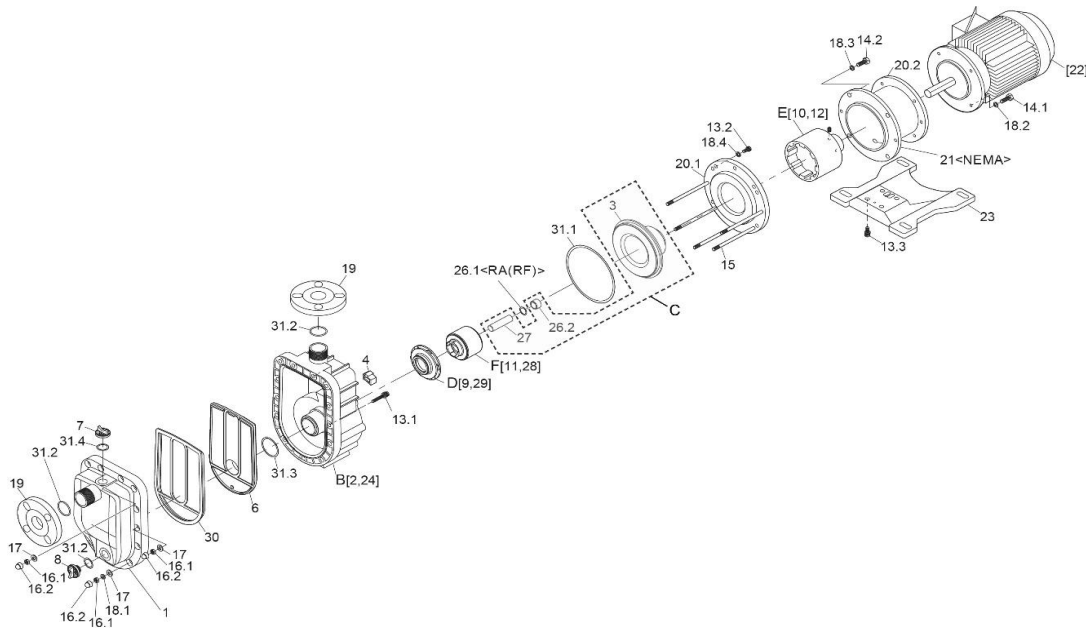

Item	Description	Q'ty	Type	Material	Part No.	Code No.	
1	Front Case	1		CFRETFE	SMF0001	1210043400	
B	Rear Case (+Liner Ring) Unit	CF•RF	1	F220•F221-V	CFRETFE+Ceramic	SMF0002	1240854110
			1	F221•F222-T		SMF0052	1240854310
		KK	1	F220•F221-V	CFRETFE+SiC	SMF0004	1240854120
			1	F221•F222-T		SMF0053	1240854320
3	Rear Casing	1		CFRETFE	SMF0006	1231196800	
C	Rear casing assembly (3,26.2,27)	1	CF	CFRETFE+Al Ceramics	SMF0166		
			RF	CFRETFE+Al Ceramics	SMF0167		
			KK	CFRETFE+SiC	SMF0168		
4	Volute Spacer	1	F220•F221-V	CFRETFE	SMF0007	1240854600	
			F221•F222-T		SMF0054	1240857900	
6	Plate	1		CFRETFE	SMF0009	1220307400	
7	Cap	1		CFRETFE	SMF0010	1240856300	
8	Drain Cap	1		CFRETFE	SMF0011	1240856500	
D	Impeller (with Mouth Ring) Unit	CF•RF	1	F220•F221-V	CFRETFE+PTFE	SMF0012	1240855010
			1	F221•F222-T		SMF0055	1240855410
		KK	1	F220•F221-V	CFRETFE+SiC	SMF0014	1240855020
			1	F221•F222-T		SMF0056	1240855420
*E	Drive Magnet Unit <*See Note below>	<E0>	1	F220 [0,37kW]	Aluminium+Magnet	MX0215	1230975600
		<J1>	1	F221 [0,75kW]	FCD450+Magnet	MX0227	1230977000
		<J2>	1	F222 [1,5kW]	FCD450+Magnet	MX0310	1230987200
F	Magnet Capsule+ Bearing Unit	F220	1	CFV•CFE	CFRETFE+Carbon.+Mag.	MX0424	1231235210
			1	RFV•RFE	CFRETFE+PTFE+Mag.	MX0425	1231235220
			1	KKV•KKE	CFRETFE+SiC+Mag.	MX0426	1231235230
		F221	1	CFV•CFE	CFRETFE+Carbon.+Mag.	MX0443	1231235310
			1	RFV•RFE	CFRETFE+PTFE+Mag.	MX0444	1231235320
			1	KKV•KKE	CFRETFE+SiC+Mag.	MX0445	1231235330
		F222	1	CFV•CFE	CFRETFE+Carbon.+Mag.	MXM0267	1231253710
			1	RFV•RFE	CFRETFE+PTFE+Mag.	SMF0067	1231253720
			1	KKV•KKE	CFRETFE+SiC+Mag.	MXM0269	1231253730
13.1	Cap Bolt with P.W. & S.W.	8	M8x40	SUS304 equivalent	MX0240	0150300508	
13.2	Cap Bolt	3	M8x15	SUS304 equivalent	SMX0059	0150300030	
13.3	Cap Bolt with P.W. & S.W.	4	M8x20	Steel	MX0219	0150900033	
14.1	Hex. Head Bolt	F220	4	M8x20	SUS304 equivalent	MDM0037	0150100163
		F221•222	4	M10x25	SUS304 equivalent	MDM0041	0150100181

*Note: "Drive Magnet Unit" is furnished with 2 x Setscrew (M8x10).

⚠ Subject to change without prior notice! ⚠ Actual pump may differ from the exploded view!

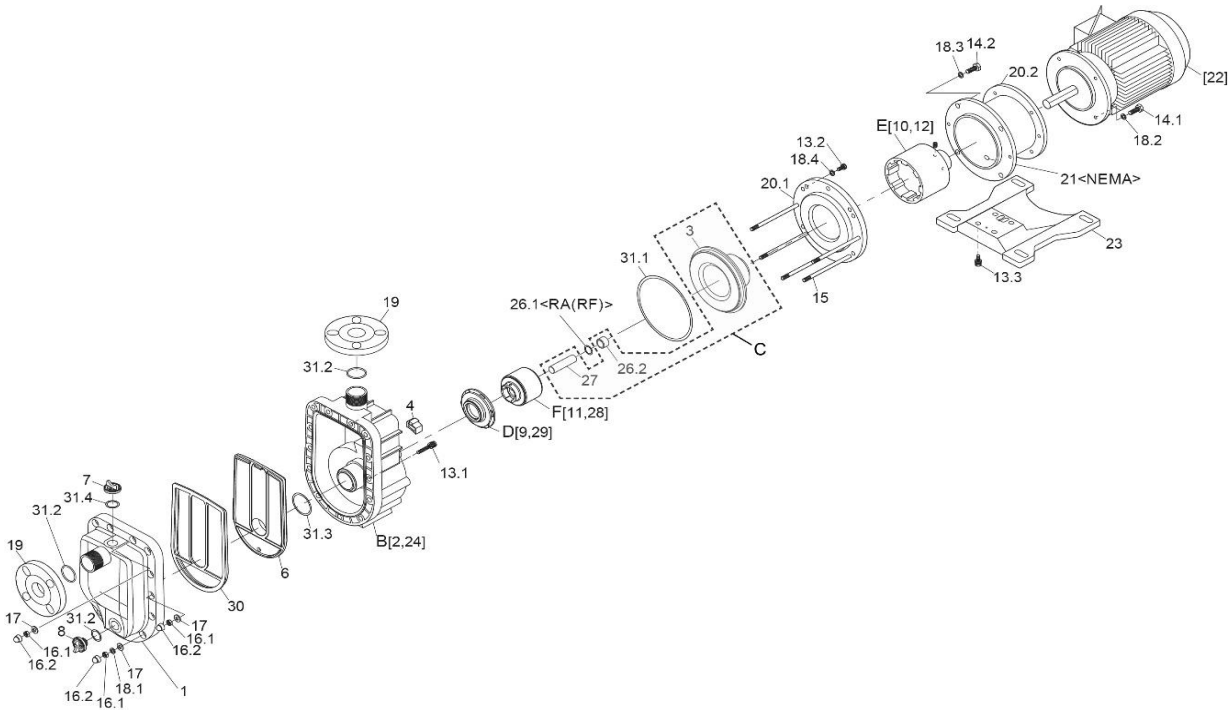

Item	Description	Q'ty	Type	Material	Part No.	Code No.	
14.2	Hex. Head Bolt	4	M10x25	SUS304 equivalent	MDM0041	0150100181	
15	Stud Bolt	5	M8	SUS304	SMX0063	1240833800	
16.1	Nut	13	M8	SUS304 equivalent	SMX0064	0153100029	
16.2	Cover Cap	13		PE	SMX0065	0159000000	
17	Plate Washer	13	M8	SUS304 equivalent	MDM0026	0153500074	
18.1	Spring Washer	5	M8	SUS304 equivalent	MDM0028	0154100057	
18.2	Spring Washer	F220	4	M8	SUS304 equivalent	MDM0028	0154100057
		F221•222	4	M10	SUS304 equivalent	MDM0030	0154100022
18.3	Spring Washer	4	M10	SUS304 equivalent	MDM0030	0154100022	
18.4	Spring Washer	3	M8	SUS304 equivalent	MDM0028	0154100057	
19	Flange	2		CFRETFE	MX0471	1240765000	
20.1	Rear Casing Support	1		FCD450	SMX0069	1231156800	
20.2	Adapter	F220	1	0,37kW	FCD450	SMX0070	1210041500
		F221	1	0,75kW	FCD450	SMX0075	1210041600
		F222	1	1,5kW	FCD450	SMX0079	1210041700
23	Base	1		GFRPP	SMX0073	1220303100	
*26.1	Rear Thrust Ring	1	"RF" type only	Alumina Ceramic	SMX0016	1240833500	
26.2	Rear Thrust		1	CF•KK	CFRETFE	MX0428	1240764700
			1	RF	CFRETFE	SMF0039	1240856600
27	Spindle		1	CF•RF	Alumina Ceramic	MX0118	1240725000
			1	KK	SiC	MX0427	1240765100
30	Gasket		1	V	FKM-A	SMF0042	1220308300
			1	E	EPDM	SMF0043	1220308400
31.1	O-Ring <G-160>		1	V	FKM-A	SMX0023	0325300186
			1	E	EPDM	SMX0024	0325300187
31.2	O-Ring <G-25>		3	V	FKM-A	MX0117	0325300203
			3	E	EPDM	MX0205	0325300179
31.3	O-Ring <P-40>		1	V	FKM-A	SMF0048	0325100137
			1	E	EPDM	SMF0064	0325100534
31.4	O-Ring <G-30>		1	V	FKM-A	SMX0029	0325300053
			1	E	EPDM	SMX0030	0325300087

⚠ Subject to change without prior notice! ⚠ Actual pump may differ from the exploded view!