

Item	Description	Q'ty	Type	Material	Part No.	Code No.	
B	Rear Case (+Liner Ring) Unit	1	220•221-V	GFRPP+Ceramic	SMX0002	1240835900	
		1	221•222-T	GFRPP+Ceramic	SMX0033	1240836100	
C	Rear casing assembly (3,26.2,27)	220	1	CA	GFRPP+Al Ceramics	SMX0150	
			1	RA	GFRPP+Al Ceramics	SMX0151	
			1	KA	GFRPP+SiC	SMX0152	
		221	1	CA	GFRPP+Al Ceramics	SMX0150	
			1	RA	GFRPP+Al Ceramics	SMX0151	
			1	KA	GFRPP+SiC	SMX0152	
		222	1	CA	GFRPP+Al Ceramics	SMX0150	
			1	RA	GFRPP+Al Ceramics	SMX0151	
			1	KA	GFRPP+SiC	SMX0152	
*4	Volute Spacer (for "V" only)	1	220•221-V	GFRPP	SMX0005	1240834700	
D	Impeller (with Mouth Ring) Unit	1	220•221-V	GFRPP+PTFE	SMX0010	1240835300	
		1	221•222-T	GFRPP+PTFE	SMX0034	1240835500	
*E	Drive Magnet Unit <*See Note below>	<E0>	1	220 [0,37kW]	Aluminium+Magnet	MX0215	1230975600
		<J1>	1	221 [0,75kW]	Ductile Iron+Mag.	MX0227	1230977000
		<J2>	1	222 [1,5kW]	Ductile Iron+Mag.	MX0310	1230987200
F	Magnet Capsule+ Bearing Unit	220	1	CAV•CAE	PP+Carbon+Mag.	MX0113	1230974710
			1	RAV•RAE	PP+PTFE+Magnet	MX0114	1230974720
			1	KAV•KAE	PP+SiC+Magnet	SMX0014	1230974740
		221	1	CAV•CAE	PP+Carbon+Mag.	MX0122	1230976410
			1	RAV•RAE	PP+PTFE+Magnet	MX0123	1230976420
			1	KAV•KAE	PP+SiC+Magnet	SMX0037	1230976440
		222	1	CAV•CAE	PP+Carbon+Mag.	SMX0038	1231159310
			1	RAV•RAE	PP+PTFE+Magnet	SMX0039	1231159320
			1	KAV•KAE	PP+SiC+Magnet	SMX0040	1231159330
14.1	Hex. Head Bolt	220	4	M8x20	SUS304 equivalent	MDM0037	0150100163
		221•222	4	M10x25	SUS304 equivalent	MDM0041	0150100181
18.2	Spring Washer	220	4	M8	SUS304 equivalent	MDM0028	0154100057
		221•222	4	M10	SUS304 equivalent	MDM0030	0154100022
20.2	Adapter	220	1	0,37kW	Ductile Iron	SMX0070	1210041500
		221	1	0,75kW	Ductile Iron	SMX0075	1210041600
		222	1	1,5kW	Ductile Iron	SMX0079	1210041700
*26.1	Rear Thrust Ring	1	"RA" type only	Alumina Ceramic	SMX0016	1240833500	
26.2	Rear Thrust	1	CA•KA	CFRPPS	MX0119	1240724900	
		1	RA	CFRPPS	SMX0018	1240833600	
27	Spindle	1	CA•RA	Alumina Ceramic	MX0118	1240725000	
		1	KA	SiC	MX0427	1240765100	

*Note: "Drive Magnet Unit" is furnished with 2 x Setscrew (M8x10).

⚠ Subject to change without prior notice! ⚠ Actual pump may differ from the exploded view!

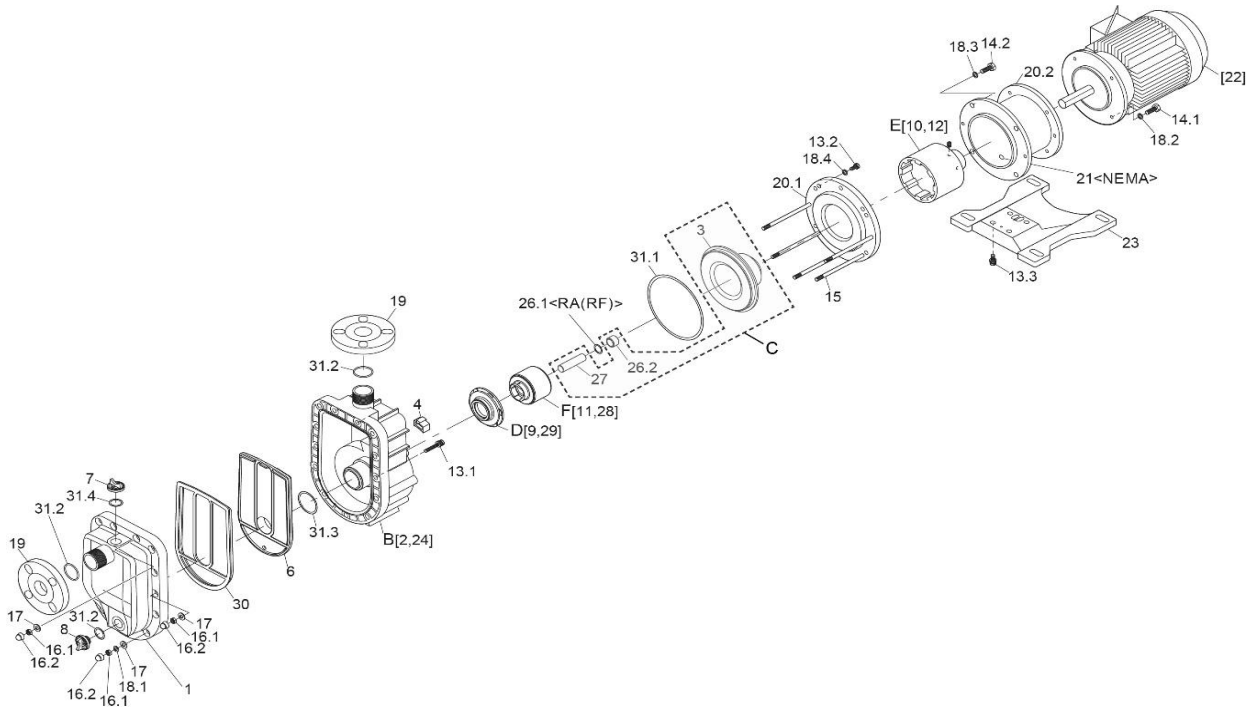

Item	Description	Q'ty	Type	Material	Part No.	Code No.
1	Front Case	1		GFRPP	SMX0001	1210041100
3	Rear Casing	1		GFRPP	SMX0004	1231156700
6	Plate	1		GFRPP	SMX0007	1220304000
7	Cap	1		GFRPP	SMX0008	1240833200
8	Drain Cap	1		GFRPP	SMX0009	1240833300
13.1	Cap Bolt with P.W. & S.W.	8	M8x40	SUS304 equivalent	MX0240	0150300508
13.2	Cap Bolt	3	M8x15	SUS304 equivalent	SMX0059	0150300030
13.3	Cap Bolt with P.W. & S.W.	4	M8x20	Steel	MX0219	0150900033
14.2	Hex. Head Bolt	4	M10x25	SUS304 equivalent	MDM0041	0150100181
15	Stud Bolt	5	M8	SUS304	SMX0063	1240833800
16.1	Nut	13	M8	SUS304 equivalent	SMX0064	0153100029
16.2	Cover Cap	13		PE	SMX0065	0159000000
17	Plate Washer	13	M8	SUS304 equivalent	MDM0026	0153500074
18.1	Spring Washer	5	M8	SUS304 equivalent	MDM0028	0154100057
18.3	Spring Washer	4	M10	SUS304 equivalent	MDM0030	0154100022
18.4	Spring Washer	3	M8	SUS304 equivalent	MDM0028	0154100057
19	Flange	2	ISO	GFRPP	MX0204	1240725100
20.1	Rear Casing Support	1		Ductile Iron	SMX0069	1231156800
23	Base	1		GFRPP	SMX0073	1220303100
30	Gasket	1	V	FKM-A	SMX0021	1220303500
		1	E	EPDM	SMX0022	1220303600
31.1	O-Ring, G-160	1	V	FKM-A	SMX0023	0325300186
		1	E	EPDM	SMX0024	0325300187
31.2	O-Ring, G-25	3	V	FKM-A	MX0117	0325300203
		3	E	EPDM	MX0205	0325300179
31.3	O-Ring, G-40	1	V	FKM-A	SMX0027	0325300055
		1	E	EPDM	SMX0028	0325300089
31.4	O-Ring, G-30	1	V	FKM-A	SMX0029	0325300053
		1	E	EPDM	SMX0030	0325300087

⚠ Subject to change without prior notice! ⚠ Actual pump may differ from the exploded view!